

5.6 THE BRAKE

5.6.0 Introduction

brake

The *brake* is used to stop a turning mill. The brake also ensures that an idle mill does not start turning, even in a storm. Because of these two vital tasks of the brake, the voluntary miller must know how to operate the brake. He must be able to carry out minor adjustments and maintenance work on the brake. He must also regularly check to see if the brake is in a good state and in proper working order. For a brake failure would make it impossible to stop the mill.

There are two types of brakes, each of which has two different versions:

1. Block brake
 - a. Flemish brake
 - b. North Holland brake
2. Strip or hoop brake
 - a. Wooden strip brake
 - b. Steel strip brake

5.6.1 Block brake

block brake
brake shoes

A *block brake* is not made of a single piece but of four or five pieces connected to each other in the shape of an arc. These pieces, the *brake shoes*, are of wood sawn from crookedly grown trees.

5.6.1a Flemish brake

Flemish brake
belly block, toe block, shoulder block, head block, sword block

The *Flemish brake* (see Fig. 5.6.1.1) encloses nearly the entire head wheel and generally consists of five brake shoes: *belly block, toe block, shoulder block, head block* and *sword block*. These brake shoes are made of willow or poplar wood. Both types of wood are soft, tough and most importantly wear-resistant.

brake anchorage

The belly block is directly or indirectly attached with a *brake anchorage* to the right-hand sheer. The brake anchorage prevents the brake from turning along with the head wheel. The bellyblock wears quickest because it is under the heaviest load when the brake is applied.

iron plates

Both sides of the brake shoes are jointly connected to arched iron strips, the *iron plates*. The iron plates are generally attached to a brake shoe over a length of some 50 to 60 centimeters. The iron plates are sunk into the center of the sides of the brake shoes and fastened with heavy nails and at least two bolts. Owing to wear of the brake shoes, the iron plates come closer and closer to the head wheel. When they almost touch the head wheel, they must be adjusted.

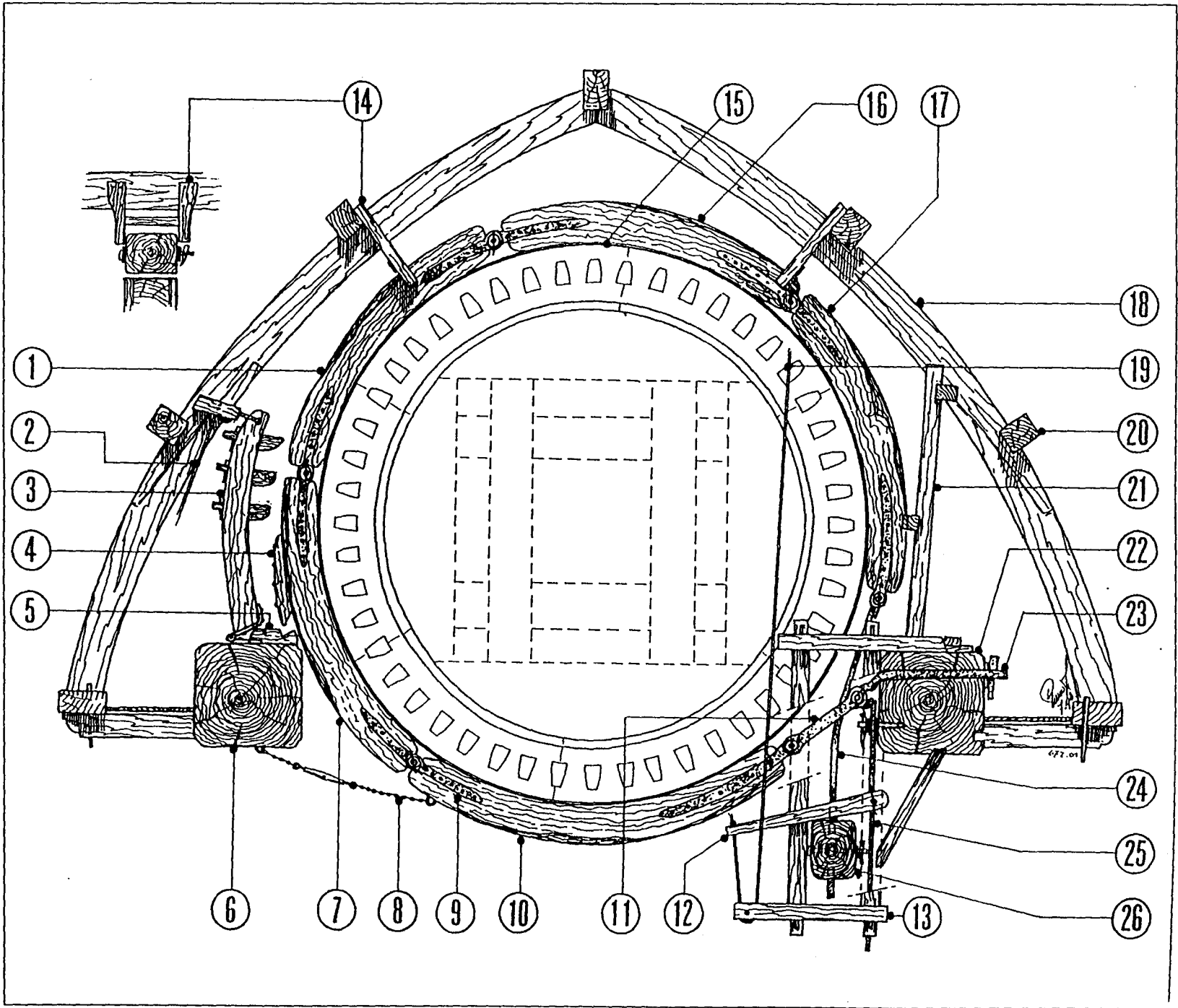

5.6.1b North Holland brake

North Holland brake
stutkast
 support

The Dutch brake (see Fig. 5.6.1.2) does not have a bellow block. In this brake a space, the '*stutkast*', has been cut into the left-hand sheer and the toe block. The space contains a wooden *support* which points into the direction of the underside of the head wheel cogs. The support is secured against falling out. It performs the same function as the brake anchorage in the Flemish brake.

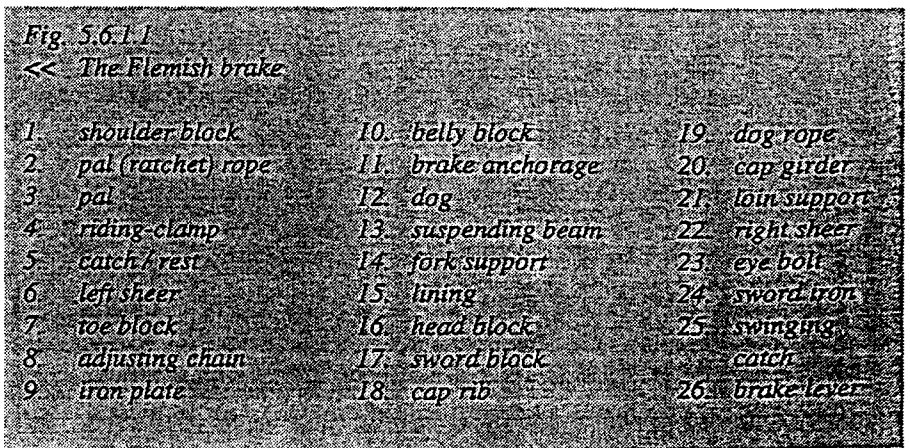

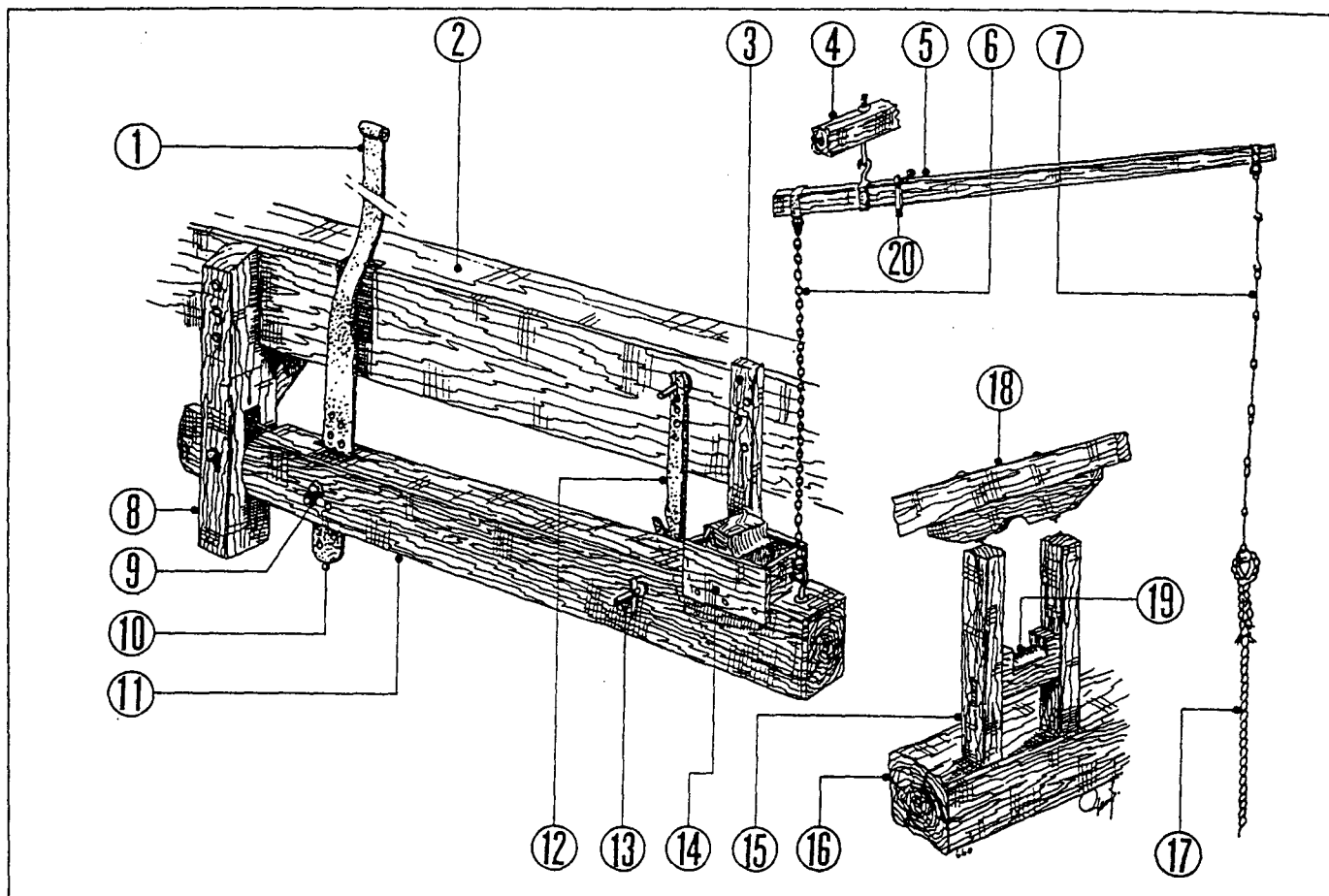

Fig. 5.6.3.1
The brake lever with concomitants

- | | | |
|------------------------|--------------------------|------------------------|
| 1. eye for sword block | 7. brake chain | 13. pin |
| 2. right sheer | 8. front hanger / donkey | 14. weight box |
| 3. (back) hanger | 9. bolt | 15. cowl post |
| 4. aftcowl beam | 10. sword iron | 16. short sprout |
| 5. brake pole | 11. brake lever | 17. brake rope / chain |
| 6. inner brake chain | 12. swinging catch | 18. brake pole |
| | | 19. rest |
| | | 20. drip lath |

5.6.3 Sword iron, brake lever, front hanger, back hanger and hangereel

5.6.3a Sword iron

sword iron

The *sword iron* forms the connection between the actual brake and the brake

lever. It is a heavy iron strip, the top of which is fitted with an eye. Inserted through this eye is a bolt, with which the sword iron is connected to the iron plates of the sword block. On the underside the sword iron has a series of holes. By means of a bolt through one of those holes, the sword iron is connected to the brake lever (see Fig. 5.6.3.1). These holes play an important role in the adjustment of the brake. For maximum braking power, the (end of the) brake lever must hang slightly lower than horizontally.

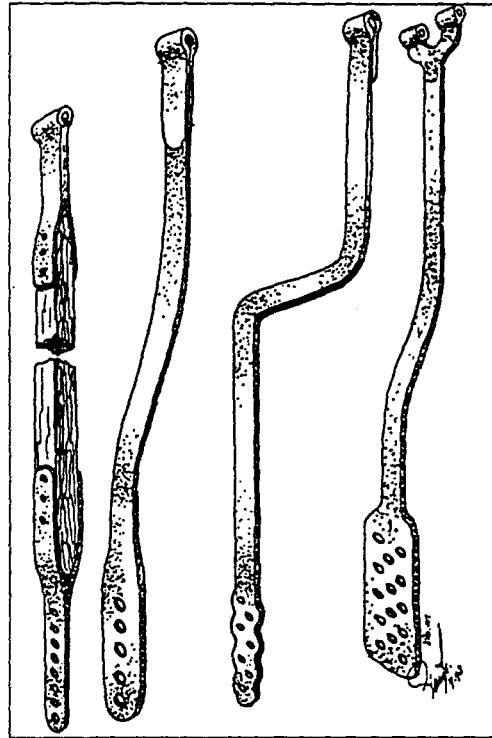

Fig. 5.6.3.2
Some examples of sword
irons

5.6.3b Brake lever

The *brake lever* is part of the control mechanism of the brake. It is a heavy oak beam with a cross-section of approximately 20 x 30 cm and a length which depends on the room in the mill. The sword iron connects the brake lever to the brake.

The brake lever has two hinge points. The first hinge point is located in the *front hanger* (see Fig. 5.6.3.3). The front end of the brake lever, fitted with a wooden or iron peg, hinges in the front hanger. About 60 to 80 cm behind it is the second hinge point, the junction point of the brake lever and the sword iron. For this connection, a vertical groove has been made in the brake lever. The sword iron passes through this groove. A horizontal hole has been drilled through the brake lever at right angles to the groove. Through this hole and through one of the holes of the sword iron, a spijlbout has been inserted and secured. The various holes in the sword iron make it possible to adjust the sword iron and the brake lever in relation to each other (see Fig. 5.6.3.1 and 2).

sword iron

front hanger or donkey

The brake lever is made as long and as heavy as possible. This increases the leverage and therefore the braking power. In many cases the back end of the brake lever is made heavier by mounting a crate on it containing a heavy object, an old neck bearing for example. In a medium-sized mill the brake lever pulls with a force of about 500 kg on the sword iron.

In most upper winders the brake lever is suspended under the right-hand shear.

The back end of the brake lever is fitted with a device used to raise the brake lever (see 5.6.6). When the brake is released, the brake lever pushes the sword iron upwards and the brake shoes separate from the head wheel. When the brake is applied, the brake lever pulls the sword iron downwards and, in doing so, clamps the brake shoes around the head wheel, thus braking the mill.

5.6.3c *Front hanger or donkey*

front hanger

The *front hanger* contains the fixed hinge point of the brake lever (see Fig. 5.6.3.3). It is a sturdy piece of wood fastened near the weather beam. In an upper winder, the front hanger, supported by several braces, is suspended from the right-hand shear. The front hanger has a vertical groove in which the peg of the brake lever is inserted. At right angles to this groove a bolt passes through the front hanger. This bolt also goes through the eye of the peg of the brake lever, thus forming the hinge point.

Fig. 5.6.3.3
Front hanger or donkey

1. *front hanger with slide*
2. *front hanger with fixed pivot point*
3. *keep*
4. *wedges*
5. *slide*
6. *bolt*
7. *split pin*

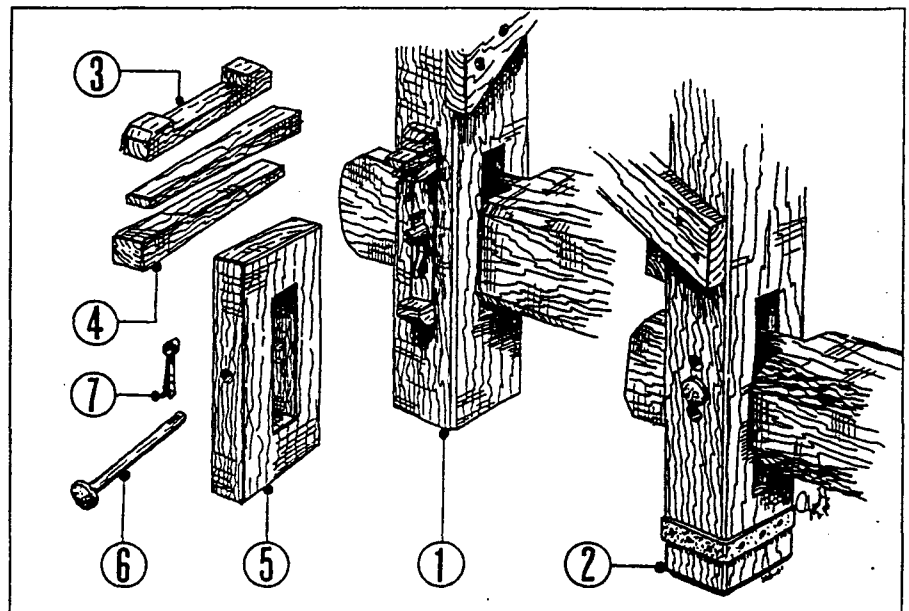

5.6.4 Riding clamp and catch, loin support, fork supports and chains

When the brake lever is released, the sword iron raises the sword block or the beginning of the hoop brake. Then the rest of the brake separates from the head wheel. However, this only happens owing to a number of guides, without which the brake would remain hanging and gliding over the head wheel due to its own weight. When the guides are adjusted properly, a released brake produces a space of approximately 1 cm between the brake and the head wheel along the entire braking surface.

5.6.4a Riding clamp and catch

When the brake lever pushes the brake loose from the head wheel, it is important that the space which is thus created between the head wheel and the brake is proportionally distributed over the entire circumference, or otherwise the brake will start dragging. This space is not created automatically, because due to its own weight the brake will drag over the head wheel, while below at the belly block a considerable space will arise between the head wheel and the brake. This is prevented as follows.

catch
riding clamp

A wooden clamp, the riding clamp, is affixed to the toe block of the brake (to a strip brake at a corresponding height). A wooden clamp with a slanted notch, the *catch*, is also affixed to left-hand shear. When the brake is released, the *riding clamp* is on the *catch*. Together they prevent the brake from sagging too far. Furthermore, due to the slanted underside, they keep the toe block at a proper distance from the head wheel (the strip brake at a corresponding height). If necessary, a fine-tuned setting can be realized (when the mill is idle) by applying one or more thin laths between the catch and the riding clamp.

If a metal strip brake is used, the riding clamp and the catch are also made of metal (see Fig. 5.6.4.1).

Fig. 5.6.4.1
Wooden and metal riding clamp and rest (or catch)

1. toe block
2. backside of brake wheel
3. riding clamp
4. rest/catch
5. iron riding clamp/rest

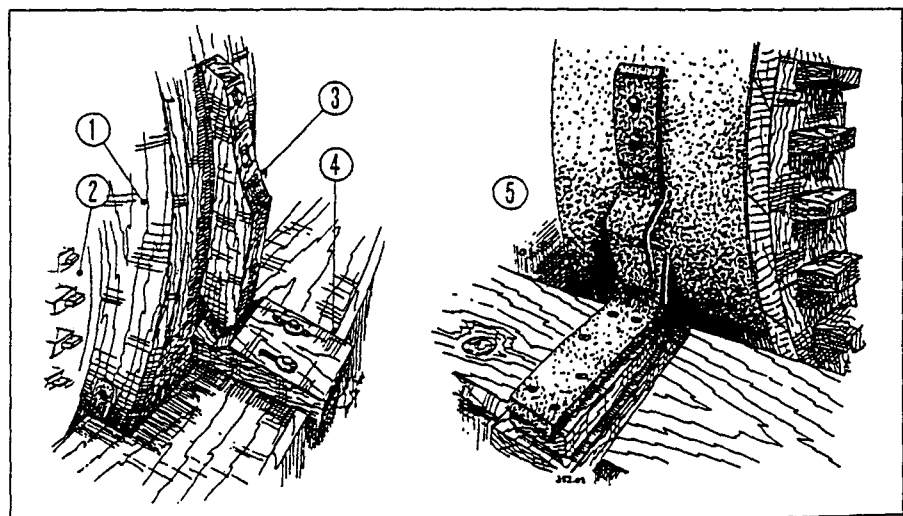

5.6.4b Loin support

loin support

The *loin support* rests on the right-hand sheer and at the top is affixed to a purlin. The loin supports guides the sword block (or the beginning of the strip brake) and prevent it being pushed too far sideward from the head wheel when the brake is released. This way, at the top the brake also separates from the head wheel. Often the loin support can also be adjusted sideward, such in connection with wear of the head wheel and the brake.

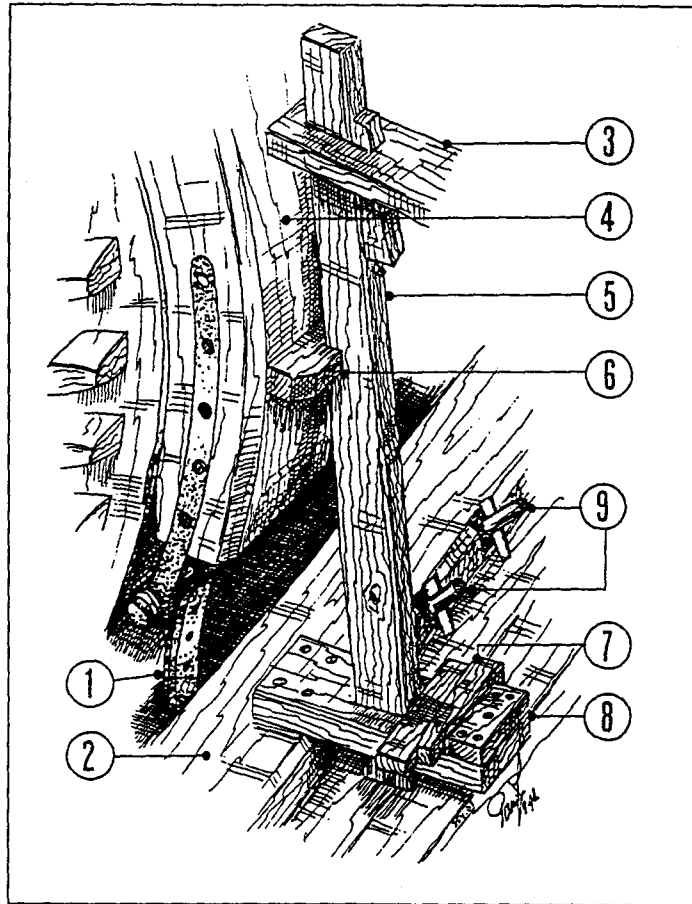

Fig. 5.6.4.2
Loin support

1. sword iron
2. right sheer
3. support on cap purlin
4. sword block
5. loin support
6. keep
7. adjusting wedges
8. support
9. brake anchorage

5.6.4e Fork supports

fork supports, chains

To prevent the brake moving back and forth, *fork supports* and *chains* have been attached to the cap ribs or the purlins (see Fig. 5.6.1.1).

5.6.5 Method of locking a released brake lever

There are various possibilities to keep a released brake lever locked in position.

Upon applying the brake, the brake lever must first be raised a little by jerking it. This will cause the bolt to let go of the hook and the hook is given a swing. As the hook is swung, the miller can lower the brake lever far enough to prevent the bolt being caught in the hook once more when the hook is back in its normal position. To do this, requires a good deal of practice.

If a hook is used to lock the brake lever, the brake lever has only to make a vertical movement.

5.6.5b Thumb

thumb, brake catch

If, instead of a hook, another device is used to lock the brake lever, it is mounted on the back hanger. The *thumb* or *brake catch* is such a device (see Fig. 5.6.5.2). It is an iron peg pointing diagonally upwards and on the underside it is embedded in the lever. Slightly below the top the peg is fitted with a bolt which passes through the back hanger. In other words, the top end sticks slightly above the bolt. The whole device resembles a thumb pointing upwards, and that is why it is called a *duim* (lit. thumb) in Dutch.

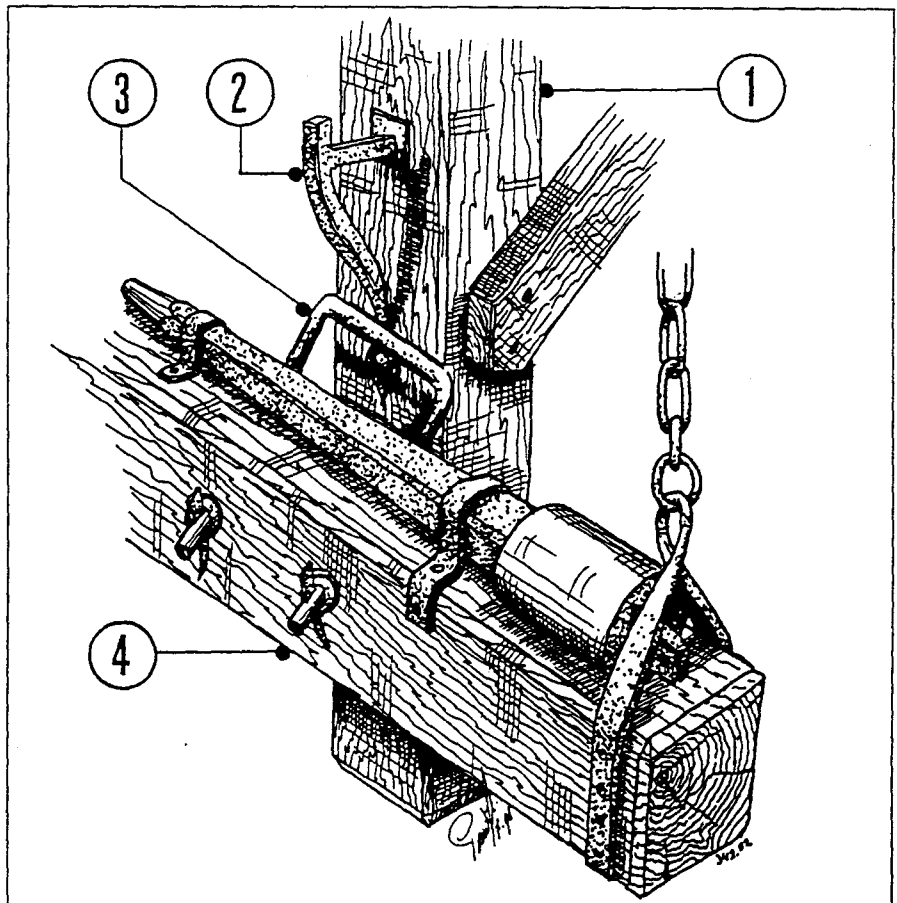

Fig. 5.6.5.2
The back hanger with
thumb

- 1. back hanger
- 2. thumb
- 3. clasp
- 4. brake lever

brake lever

At the place of the brake catch, a bow is attached on the right-hand side of the *brake lever*. When the brake lever is released, the bow slides upwards along and against the brake catch. When the bow has passed the brake catch, the miller can lower the brake lever again. The bow will then fall into the brake catch and the brake lever is locked. In this case, too, the miller must check that the bow is not hanging on the top of the brake catch. If it is, the danger exists that the bow will slip off the wrong (left-hand) side of the bow top. The brake will then suddenly be placed on the mill, possibly causing the wind shaft to break.

To brake the mill, the miller must slightly raise (the back end) of the brake lever, so that the bow rises above the top of the brake catch. The miller must then move the brake lever slightly to the left, otherwise the bow will go back into the brake catch if the brake lever is lowered before the brake is placed on the mill. This shows that if a brake catch is used, the brake lever must not only be able to make a vertical movement but also a sideward movement.

5.6.6 Releasing and applying the brake

There are several systems for releasing a brake. These systems differ per region.

5.6.6a Brake pole

brake pole

The *brake pole* (see Fig. 5.6.3.1) sticks out of the back of the cap of an upper winder or out of the upper house of a wip mill. The brake pole is hung on the after cowl beam or wolfsbalk with a bow or bolt. Its inside end is connected to the back end of the brake lever with a chain, the *inner catch chain*.

inner catch chain

brake chain

The *brake chain* is affixed to the other end of the brake pole. The brake chain amply extends to the ground, the mound or the stage. To enhance the grip, the underside of the brake pole is fitted with a rope, the *brake rope*, or with wooden beads, the so-called *druiven* (lit. grapes).

brake rope

When the miller pulls the brake rope or the brake chain, the outside end of the brake pole goes down but the inside end goes up. Via the inner brake chain connected to the inside end, the brake lever then also rises.

A disadvantage of the brake pole is that it is subject to every kind weather. Because the brake pole points diagonally upwards when the mill is idle, rainwater will trickle down the pole into the mill. This can best be prevented by applying drip laths or a piece of rope round the brake pole just outside of the cap.

When the brake lever is locked in a hook, the brake can be released and applied in the manner described in 5.6.5a.

The brake of a mill equipped with a brake catch is released as follows. The miller pulls the brake pole downwards as far as possible. The back end of the brake lever will then rise as far as possible. Next, the miller walks a little to the left (with his face towards the sails). This causes the inside end of the brake pole, and hence also the brake lever, to move to the right. As a result, the back

end of the brake lever touches the back hanger. At that moment, the miller can carefully lower the brake lever until the back end of it slips into the brake catch.

A brake equipped with a brake catch is applied as follows. The miller first releases it. Next, he walks a little to the right (with his face towards the sails). This sideward movement will cause the inside end of the brake pole to move to the left and therefore also the back end of the brake lever. The brake lever can then be lowered into the brake catch.

5.6.7 Securing the brake

There are several devices used to secure the brake when the mill has stopped at the end of a working day.

5.6.7a Dog

dog The *dog*, a sturdy piece of wood with a cross-section of about 7x10 cm and a length of 75 to 100 cm, is used to secure the brake lever in applied position. The one end of the dog has a fixed hinge point in the form of a bolt at the back end of the applied brake lever. The dog moves at right angles to the brake lever. To secure the brake, the miller uses a rope, the *dog rope*, which is attached to the removable end of the dog, to pull the dog tightly over the back end of the brake lever. He then fastens it, usually under the tail (pole). This pulls the brake lever down a bit further so that the sword iron tightens the brake even more.

In an upper winder the dog is in the hangereel.

In its turn, the dog can be secured with a rope (the safety rope) or a bolt (the safety pin) which can be inserted into one of the series of holes in the hangereel. This prevents the brake from being accidentally released.

5.6.7c Pal/Ratchet

When the wind blows from the rear, the sails have a tendency to revolve backwards. When the wind is very strong, the brake wheel can even release the brake by simply overcoming the force exerted by the weight of the brake lever.

pal At all cost it must be prevented that the brake wheel rotates backwards. The device used to prevent this is a *pal* (see Fig. 5.6.7.1). The *pal* is a sturdy beam which is hinged to the left-hand sheer near the brake wheel. This beam has three or four cogs with the same pitch as the cogs of the brake wheel. These cogs have a flat top. When the mill has been stopped at the end of the working day, the hatchet with its cogs is lowered into the cogs of the head wheel. The bottom of the cogs of the *pal* are round. This roundness ensures that, if the miller fails to pull out the *pal* at the start of a new working day, the cogs of the brake wheel will push the hatchet out of the wheel. After each passage of a brake wheel cog, however, the *pal* falls back, thus producing a distinct thumping sound. The miller pulls the *pal* out of the brake wheel using a *pal rope*. This rope is attached to the top of the *pal* and via several rope discs reaches to the lower end of the tail. A

second rope, to which a counterweight is attached, ensures that the pal falls into the brake wheel when the pal rope is untied.

N.B. The pal may only be used to secure an idle mill from turning backwards. No attempt must ever be made to lower the pal in a mill which is already turning backwards, for this will undoubtedly cause the cogs of the pal and several cogs of the brake wheel to break.

Fig. 5.6.7.1
Pal

1. pal rope
2. pal
3. half round cog
4. hinge point
5. lat shear
6. rope for counter weight

